

GD 930 & GD 930S2

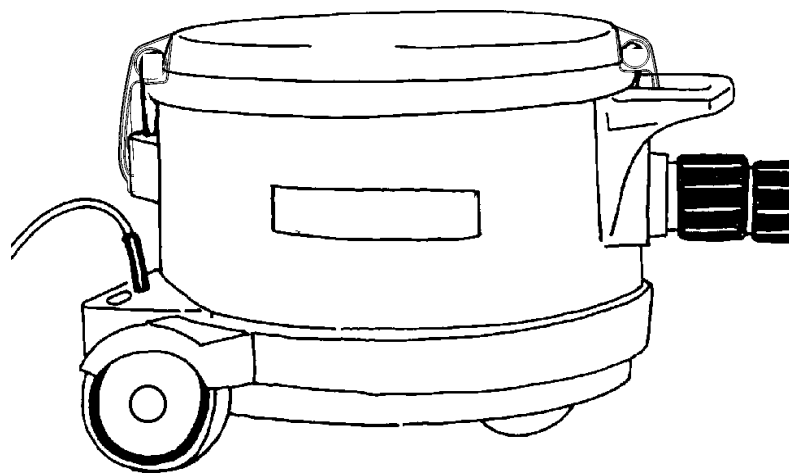
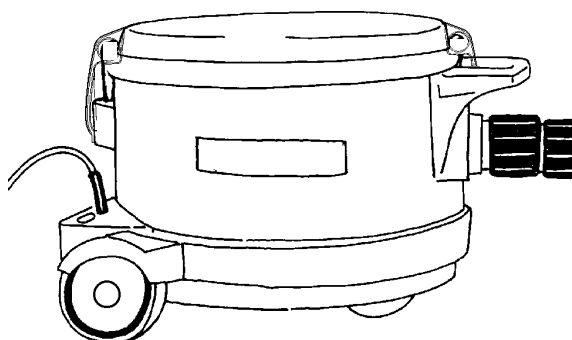

PARTS LIST

822 9401 000
56042413
2000-08

TABLE OF CONTENTS SPARE PARTS**00-08****GD 930 & GD 930S2DRY VACUUM CLEANER****3****DESCRIPTION****PLAN**

Lower parts, line-drawings	4
Lower parts, part number	5
Fan unit Line drawing	6
Table with fan units, sleeves and cords	7
Upper parts, line-drawings	8
Upper parts, part number	9
Nozzles, line drawings	10
Nozzles, part number	11
Nozzle, line drawings	12
Nozzle, part number	13
Hose, line drawing	14
Hose, part number	15
Tubes, line drawing	16
Tubes, part number	17
Wiring diagrams	18-24

SPARE PARTS

4

GD 930 GD 930S2 LOWER PARTS

00-08

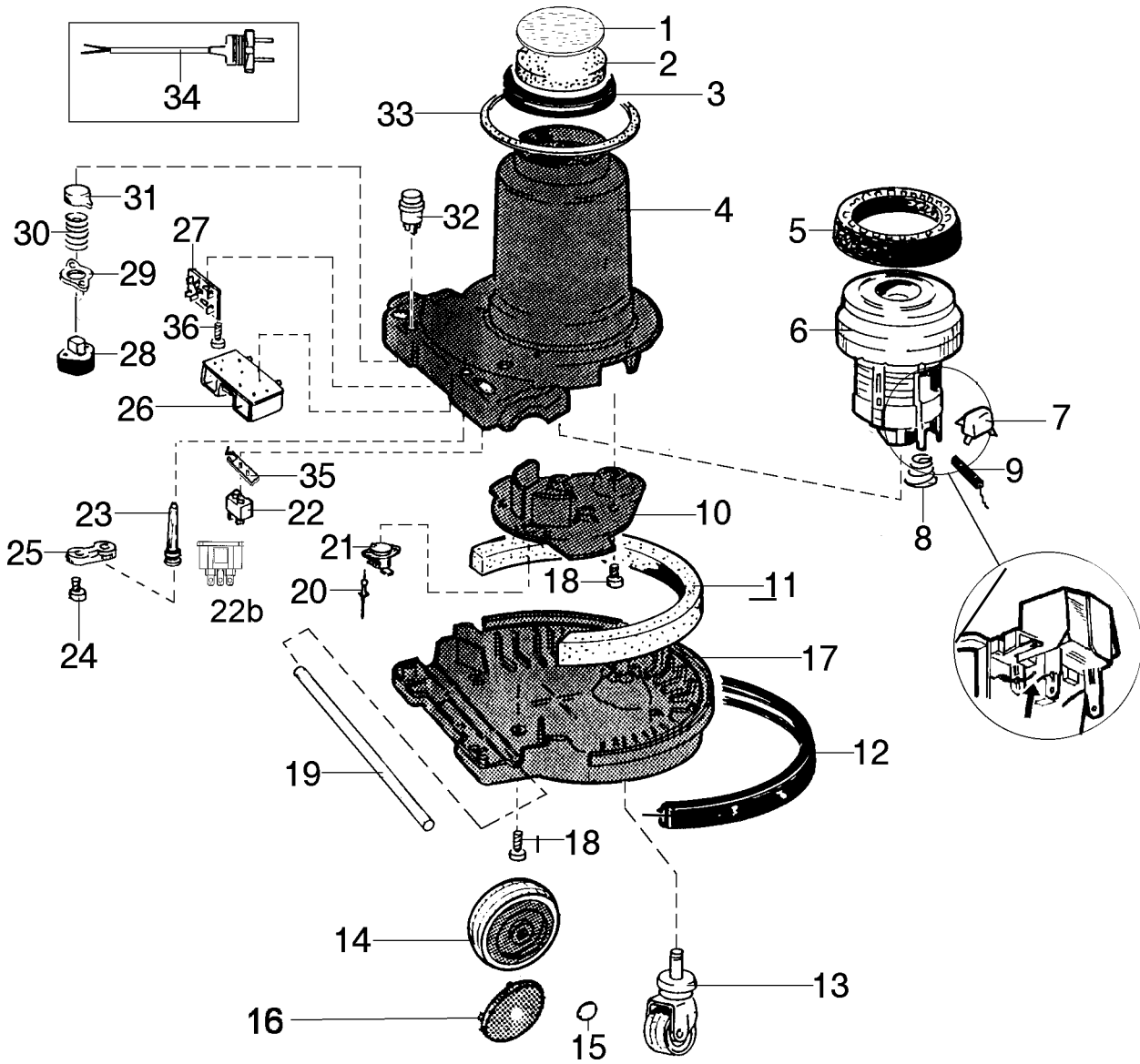

SPARE PARTS**00-08****GD 930 GD 930S2 LOWER PARTS****5**

Item No.	Qty.	Part no.	Description
1	1	140 3261 000	Paper filter
2	1	140 1535 000	Filter
3	1	140 2847 000	Gasket
4	1	140 7010 000	Stand, regular GD 930
	1	140 7010 010	Stand, S2 versions
	1	140 7010 030	Stand UL-listed, for model 905 5313
	1	140 7010 080	Stand, UL-listed, for model 905 5314
	1	140 7010 090	Stand, S2 UL-listed for model 905 5345
5	1	140 7901 000	Suspension ring, for the new domel motors
	1	011 1548 000	Suspension ring, for the old type of motor
6	1		Fan unit (see table)
7	1	140 8166 010	Capacitor
8	4	140 7016 000	Spring
9	2	001 8619 110	Carbon brush
10	1	140 7012 000	Motor plate
	1	140 7012 010	Motor plate UL-listed
11	1	140 7022 000	Silencer
12	1	140 7018 000	Bumper
13	1	140 7025 000	Castor wheel
14	2	140 5055 010	Wheel
15	2	140 5058 000	Locking cap
16	1	140 7835 000	Wheel disc
17	1	140 7011 000	Bottom part
	1	140 7011 010	Bottom part UL-list.
18	14	140 9214-070	Screw PTK 50*14
19	1	140 5059 000	Shaft
20	2	140 5694 000	Rivet
21	1	140 3894 000	Thermo switch
22	1	010 9678 000	Extra outlet
22b	1	140 7665 000	Electrical outlet (USA)
23	1		Sleeve (see table)
24	2	140 9214 040	Screw PTK 40*14
25	1	056 1014 060	Anti strain clip
	1	140 6560 000	Strain clamps UL-list
26	1	140 7026 000	Circuit board S2 220-240V
	1	140 7026 010	Circuit board S2 100-120V
27	1	140 7024 000	Anti static board
28	1	140 7033 000	Switch
29	1	140 1508 000	Washer
30	1	140 1522 000	Spring
31	1	140 7805 010	Push button, silver
32	1	140 7023 000	Switch S2 version
33	1	140 7021 000	Gasket
34			Cord set (see table)
35	1	011 7365 000	Protection plate
36	1	140 7027 000	Screw

SPARE PARTS

6

FAN UNIT LINE DRAWING

00-08

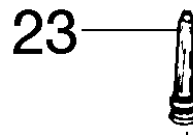
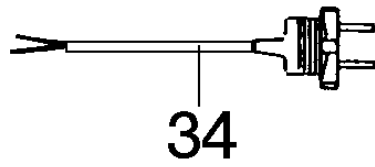
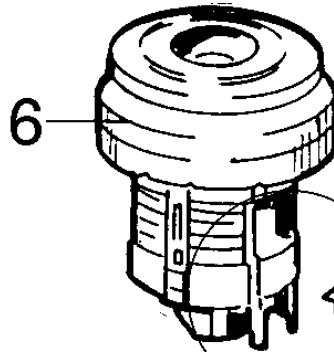

SPARE PARTS**00-08****FAN UNITS & CORDS TABLE****7**

Prod.no	Voltage	Fan unit pos.6	Sleeve pos.23	Cord pos.34
905 5301	230V	>> 140 7902 500	140 7035 000	140 6423 230
905 5302	230V	>> 140 7902 500	140 7035 000	140 6423 020
905 5303	230V	>> 140 7902 500	140 7035 000	140 6423 120
905 5304	240V	>> 140 7902 520	093 1027 010	140 6423 060
905 5305	240V	>> 140 7902 520	093 1027 010	140 6423 060
905 5306	240V	>> 140 7902 520	093 1027 010	140 7039 000
905 5307	110/120V	>> 140 7902 510	093 1027 010	140 6423 100
905 5308	100V	>> 140 7902 530	093 1027 010	140 6423 050
905 5309	230V	>> 140 7902 500	140 7035 000	140 6423 230
905 5310	220V	>> 140 7902 500	093 1027 010	140 7043 000
905 5311	220-230V	>> 140 7902 500	093 1027 010	140 6423 110
905 5312	220V	>> 140 7902 500	140 7035 000	140 6423 120
905 5313	120V	>> 140 7902 510	093 1027 010	140 3859 020
905 5314	120V	>> 140 7902 510	093 1027 010	140 3859 020
905 5315	127V	>> 140 7902 540	> 093 1027 010	140 6423 100
905 5340	230V	>> 140 7902 500	140 7035 000	140 6423 230
905 5341	240V	>> 140 7902 520	093 1027 010	140 6423 060
905 5342	240V	>> 140 7902 520	093 1027 010	140 7039 000
905 5343	100V	>> 140 7902 530	093 1027 010	140 6423 050
905 5344	230V	>> 140 7902 500	140 7035 000	140 6423 120
905 5345	120V	>> 140 7902 510	093 1027 010	140 3859 060

>> Means: New or changed ref. number or/and changed/new specifications

NOTE: New fan units for all GD 930 and GD 930S2 machines.

The spare fan units, will be delivered in a kit with the suspension ring, cables, suppressor & wiring diagram in a package.

SPARE PARTS

8

UPPER PARTS

00-08

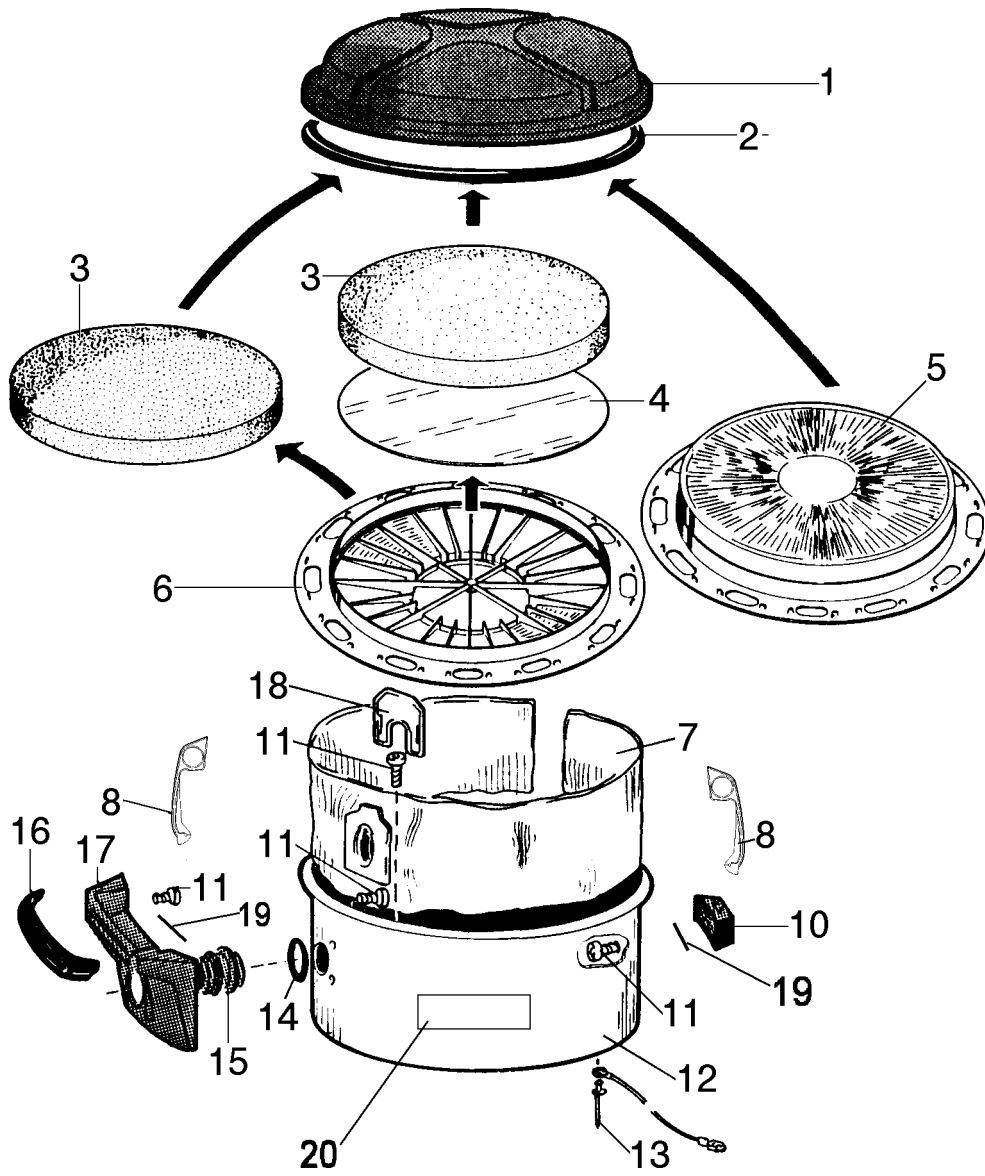

SPARE PARTS**00-08****UPPER PARTS****9**

Item	Qty.	Part No	Description
1	1	140 7802 040	Cover
2	1	140 0061 030	Gasket
3	1	140 1515 010	Filter
4	1	140 3260 000	Paper filter
	1	140 5661 000	Hygiene filter
5	1	140 2666 010	Micro filter
6	1	140 2911 000	Filter holder
7		140 7015 040	Dust bag (10 pcs)
	1	140 7019 000	Cloth dust bag
8	2	140 7832 000	Snap locking
10	1	140 7834 000	Support
11	8	140 9214 070	Screw PTK 50*14
12	1	140 7020 010	Container (chrome)
	1	140 7020 020	Container (paint.inside)
	1	140 7020 030	Container (grey painted outside)
13	1	140 5694 000	Rivet
14	1	740 4416 000	O-ring
15	1	140 7013 000	Inlet
16	1	140 7800 000	Handle protection
17	1	140 2915 050	Handle
18	1	140 7014 000	Dust bag lock
19	2	140 7807 000	Wire spring
20	2	140 7877 000	Decal Nilfisk GD 930
	2	140 7878 000	Decal Nilfisk GD 930 S2
	2	140 7879 000	Decal Euroclean GD 930
	2	140 7880 000	Decal KENT GD 930
	2	140 7298 000	Decal Jydsk
	2	140 7698 000	Decal Aquatech
	2	140 7172 000	Decal Yamazaki

SPARE PARTS

10

NOZZLES

00-08

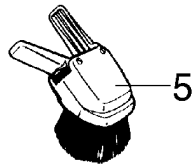
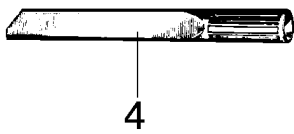
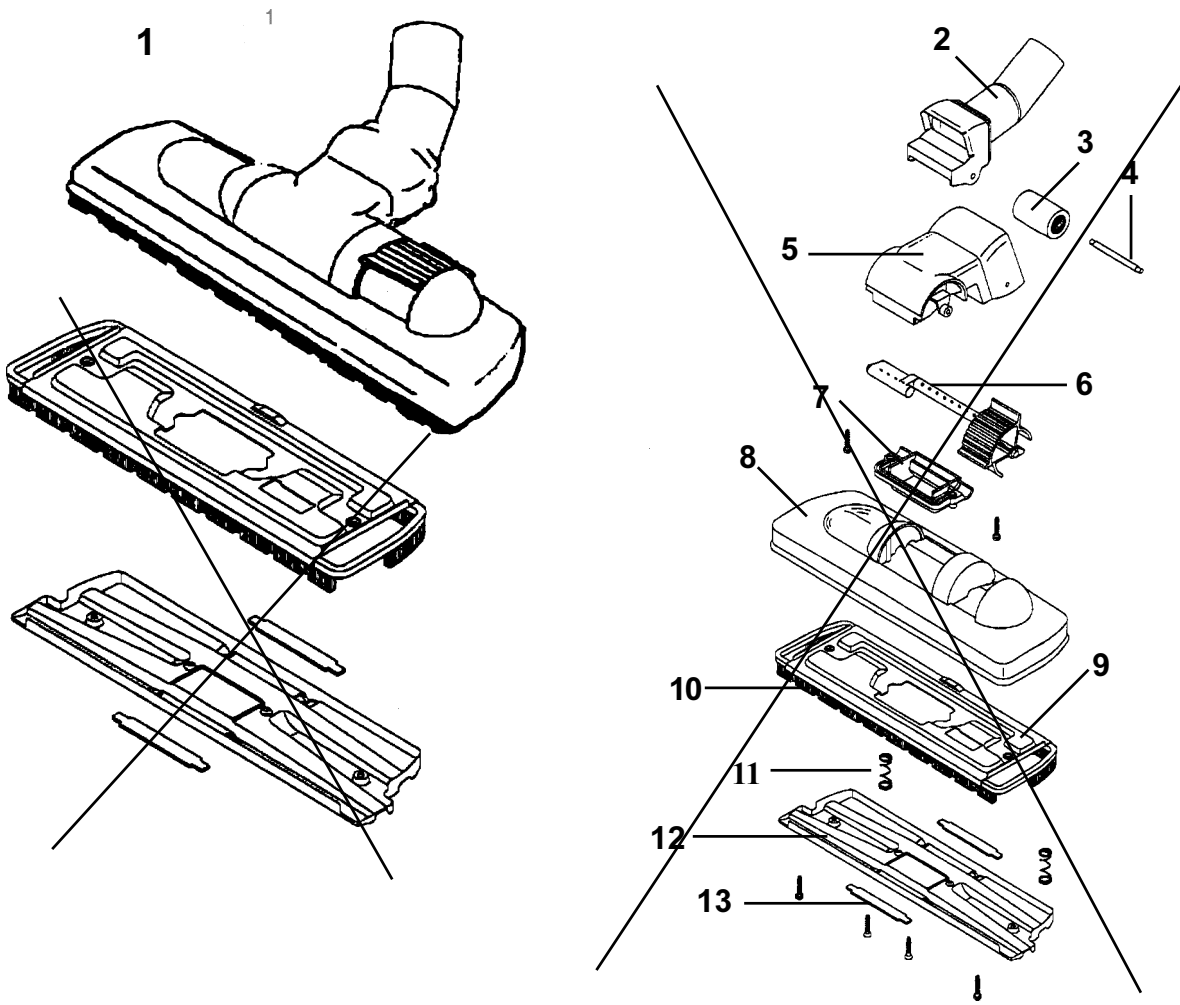

SPARE PARTS**00-08****NOZZLES****11**

<u>Item</u>	<u>Qty</u>	<u>Part No</u>	<u>Description</u>
1		140 7087 000	Combi nozzle
2	1	P 145 9921 000	Elbow
3	1	P 145 9922 000	Roll
4	1	P 145 9923 000	Shaft
5	1	P 145 9924 000	Suction channel
6	1	P 145 9925 000	Pedal
7	1	P 145 9926 000	Square moulding
8	1	P 145 9927 000	Cover
9	1	P 145 9928 000	Base plate
10	1	P 145 9929 000	Brush strip
11	2	P 093 1811 000	Spring
12	1	P 145 9930 000	Bottom plate
13	2	P 093 1813 000	Little picker

Screw/Skruv LKS KA 35x27
Screw/Skruv LSKS KA 35x16

NOTE

P means: Parts for nozzle 140 7087 000 is depleted
when no longer on stock

<u>Item</u>	<u>Part No</u>	<u>Description</u>
4	010 3098 250	Crevice nozzle
5	011 3104 230	Small comb. nozzle

SPARE PARTS

12

COMBI NOZZLE

00-08

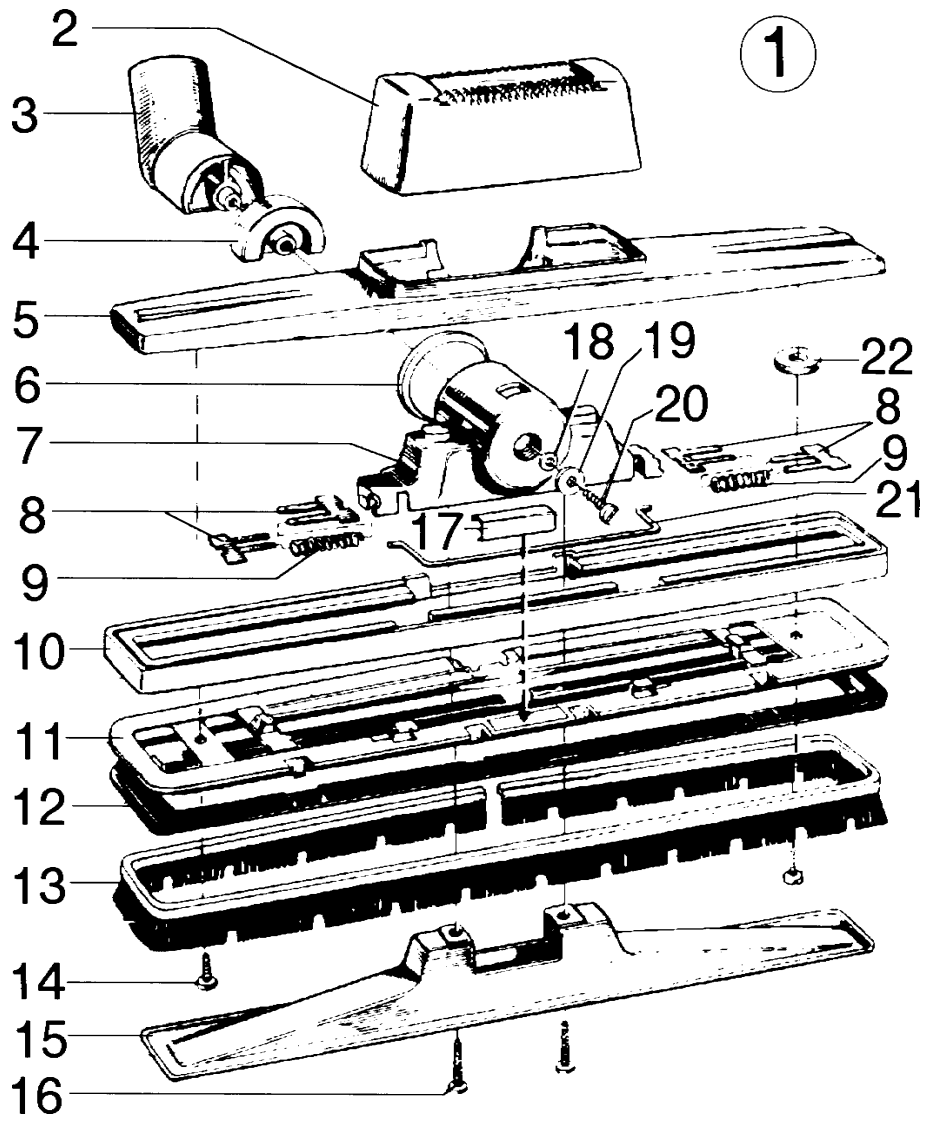

SPARE PARTS**00-08****COMBI NOZZLE****13**

<u>Item</u>	<u>Qty.</u>	<u>Part No</u>	<u>Description</u>
1		011 2332-020	Comb. nozzle, cpl.
2	1	010 6596 010	Thread comb, grey
3	1	010 3144 000	Connection tube
4	1	010 6575 000	Front bearing bush
5	1	010 6586 040	Cover, brown
6	1	010 6581 010	Bearing bush
7	1	010 9861 000	Keeper
8	4	010 6568 000	Retainer
9	2	010 6567 000	Spring
10	1	010 9860 010	Protection bar
11	1	010 9867 000	Brush holder
12	1	010 9868 000	Gasket
13	1	010 6562 000	Bristle insert
14	2	729 5281 010	Screw, RXS B6*12, Z.PI.
15	1	011 2333 000	Nozzle
16	2	729 5285 010	Screw, RXS B6*19, Z.PI.
17	1	010 9859 000	Mounting plate
18	1	735 1136 010	Washer, Ø4.3, Z.PI.
19	1	734 1136 010	Washer, Ø4.3, Z.PI.
20	1	724 1287 010	Screw, MRX M4*8, Z.PI.
21	1	010 6565 000	Loop schackle
22	1	014 9536 000	Washer

SPARE PARTS

14

HOSE WITH PARTS

00-08

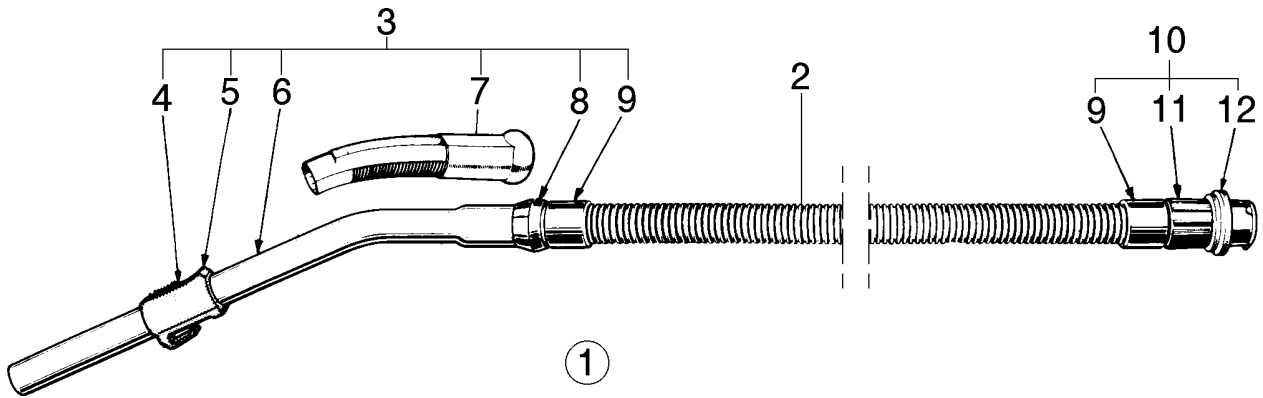

SPARE PARTS**00-08****HOSE WITH PARTS****15**

Item	Qty.	Part No	Description
1	1	140 2782 060	Hose cpl.
2	1	140 2781 020	Hose, by the metre
3	1	140 5116 000	Bent end piece cpl.
4	1	010 9613 080	Suction control
5	1	010 9614 080	Retainer
6	1	011 6432 510	Bent end piece
7	1	011 1811 070	Handle
8	1	011 1655 020	Protection ring
9	2	140 6630 000	Sleeve
10	1	140 3846 000	Cuff cpl.
11	1	011 1659 030	Outer sleeve
12	1	010 9299 040	Cuff

SPARE PARTS

16

TUBES

00-08

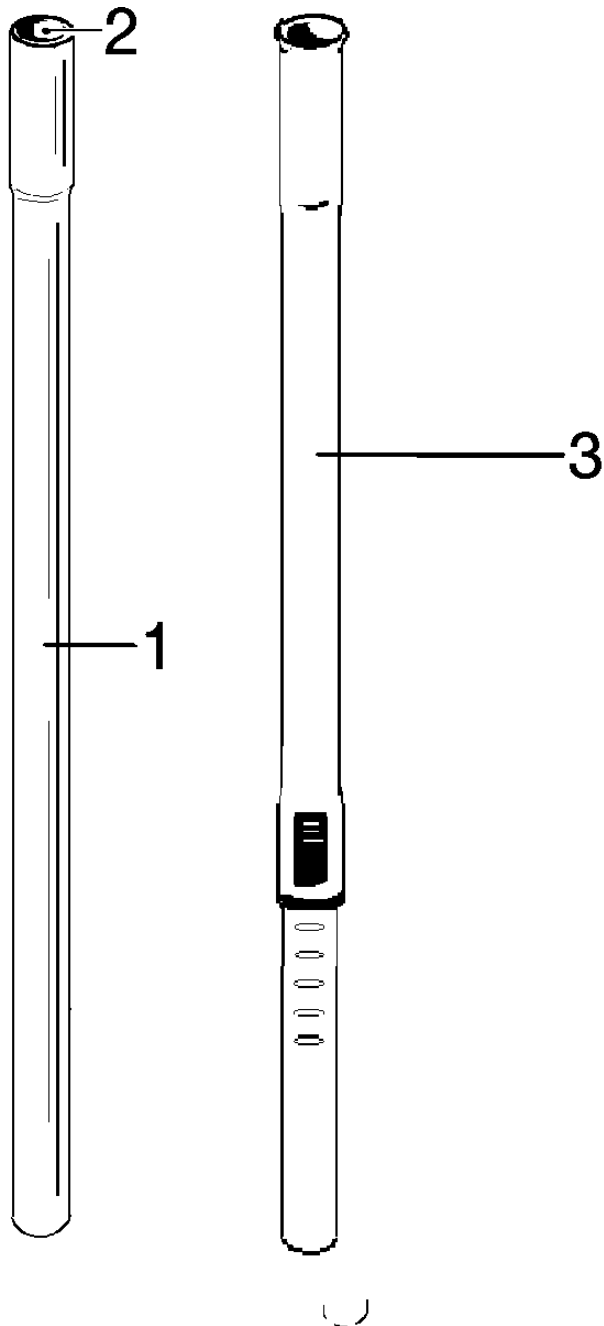

SPARE PARTS**00-08****TUBES****17**

<u>Item</u>	<u>Part No</u>	<u>Description</u>
1	011 6431 040	Extension tube, 500 mm
	011 6431 030	Extension tube, 200 mm
	011 6431 010	Extension tube, 750 mm
	011 6431 020	Extension tube, 410 mm
2	011 3199 010	Insert
3	011 8130 040	Telescop. extension tube

ELECTRICAL DIAGRAM

18

GD 930 GROUNDED VERSION

00-08

FOR THE NEW DOMEL
FAN UNITS

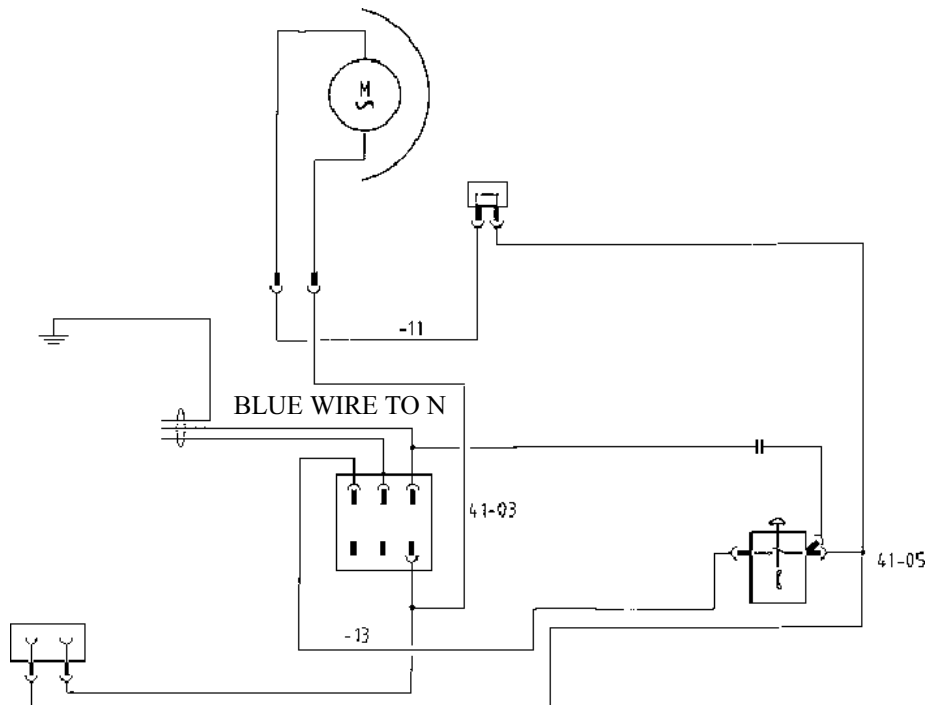

FOR THE NEW DOMEL
FAN UNITS

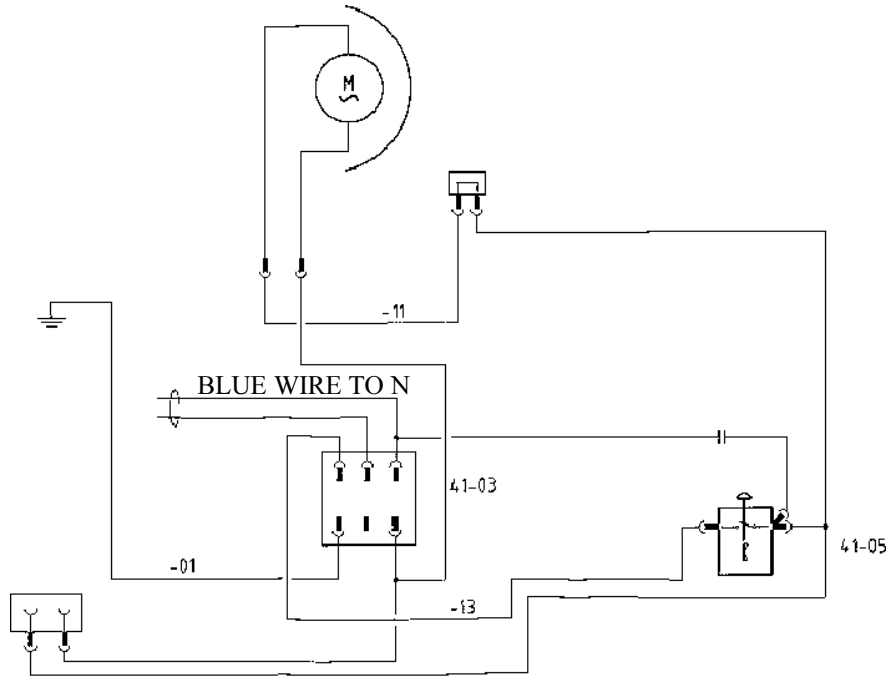

FOR THE NEW DOMEL
FAN UNITS

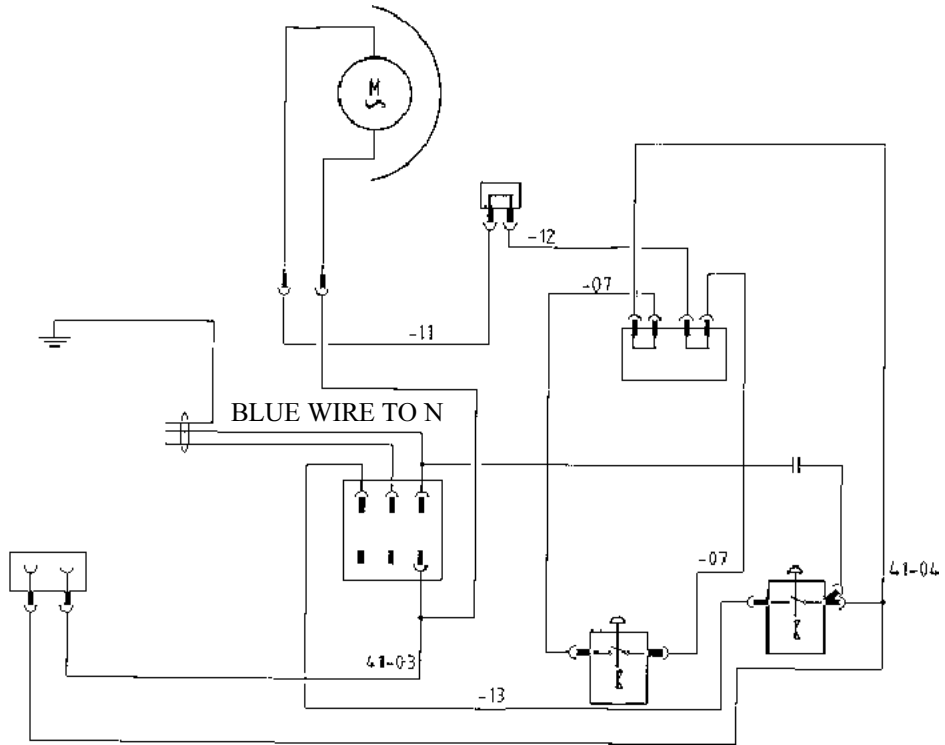

FOR THE NEW DOMEL
FAN UNITS

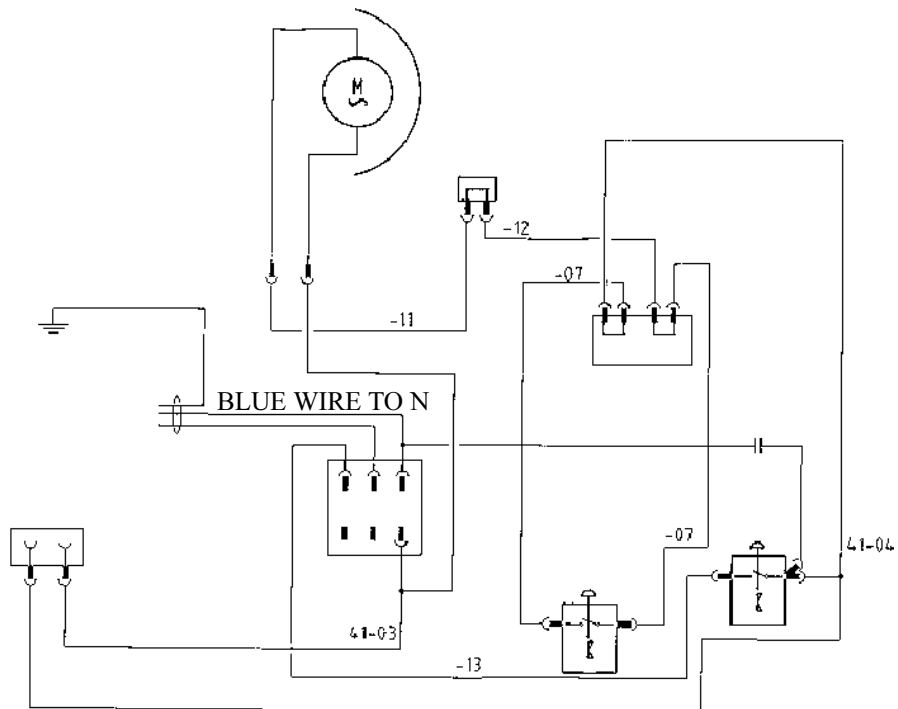

ELECTRICAL DIAGRAM

22

GD 930 GROUNDED W.OUT POWER OUTLET, US 00-08

FOR THE NEW DOMEL
FAN UNITS

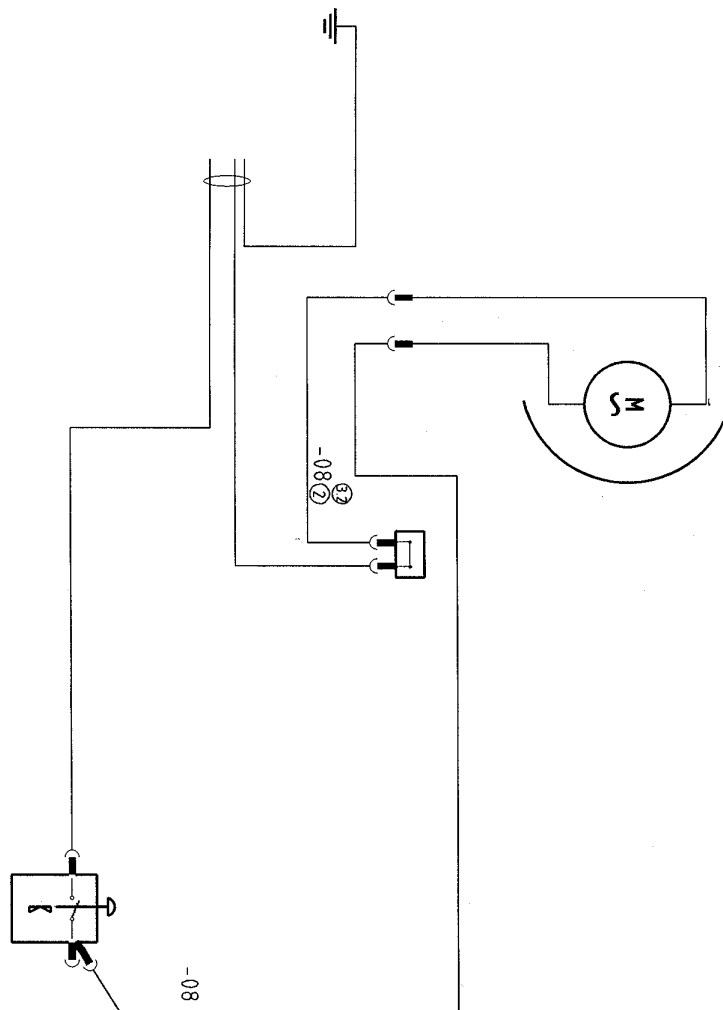

ELECTRICAL DIAGRAM

00-08

GD 930S2 GROUNDED US VERSION

23

FOR THE NEW DOMEL
FAN UNITS

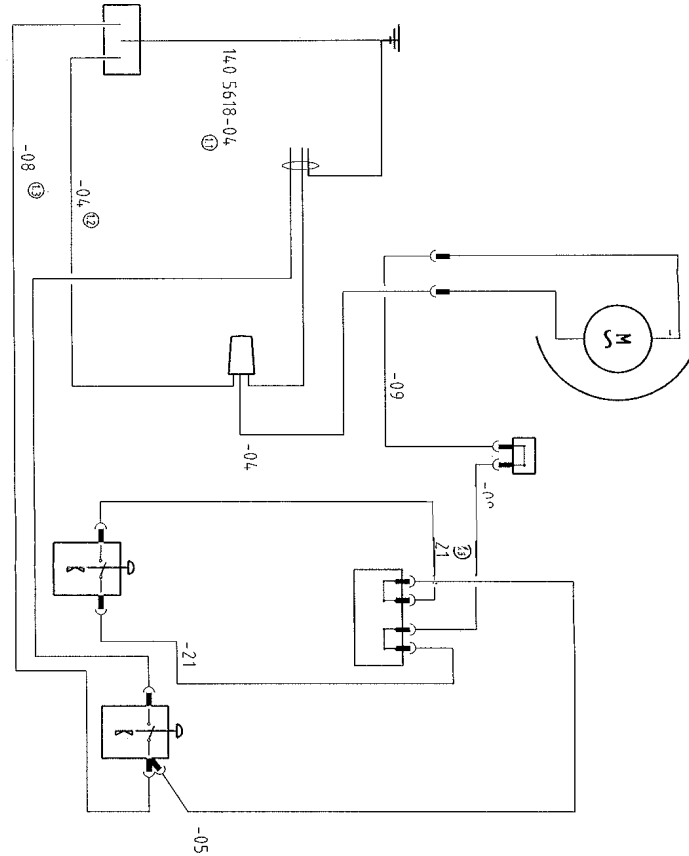

ELECTRICAL DIAGRAM

24

GD 930 GROUNDED, POWER OUTLET US

00-08

FOR THE NEW DOMEL
FAN UNITS

